

## ***NEW PRODUCT SPEC SHEET***

### **Application:**

- Recommend for AMD Processor, Socket AM4
- Active Cooler For 2U Server

### **Overall Specification:**

- Dimension: 107 x 78 x 67 mm
- Weight: 400 g
- 6028 Side-Blow Fan with PWM Function
- Material: Aluminum Stacked Fin with Heat Pipes directly contact CPU
- Convenient Heat Sink Captive Mounting
- Thermal Grease Shin-Etsu 7762 Pre-printed
- Support CPU Power 105 Watts Heat Dissipation

### **Fan Specification:**

- Model Number: DF126028BL - PWMG
- Dimension: 60 x 60 x 28 mm
- Bearing: Double-Ball
- Rated Voltage: 12V
- Rated Speed:
  - At Duty Cycle 0~20% : 1500±10% RPM
  - At Duty Cycle 50% : 3500±10% RPM
  - At Duty Cycle 100% : 7000 RPM Min.
- Rated Input Power:
  - At Duty Cycle 0~20% : 0.60 W
  - At Duty Cycle 50% : 2.16 W
  - At Duty Cycle 100% : 7.20 W

- Rated Airflow:
  - At Duty Cycle 0~20% : 8.8 CFM
  - At Duty Cycle 50% : 20.3 CFM
  - At Duty Cycle 100% : 40.5 CFM
- Rated Static Pressure:
  - At Duty Cycle 0~20% : 0.7 mm-H<sub>2</sub>O
  - At Duty Cycle 50% : 3.6 mm-H<sub>2</sub>O
  - At Duty Cycle 100% : 14.3 mm-H<sub>2</sub>O
- Rated Acoustical Noise:
  - At Duty Cycle 0~20% : 16.0 dBA
  - At Duty Cycle 50% : 32.9 dBA
  - At Duty Cycle 100% : 47.5 dBA
- Lead Wire Pin Out Diagram :

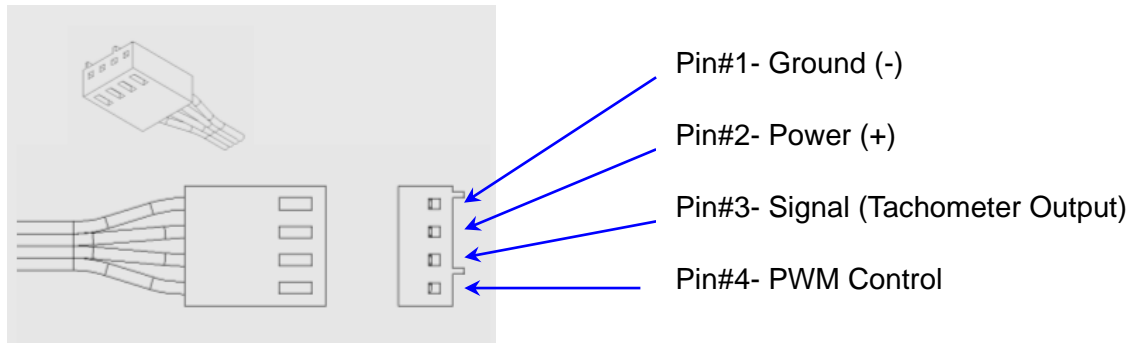

### Active Cooler A24 Cooling Performance VS. Fan Speed & Noise:

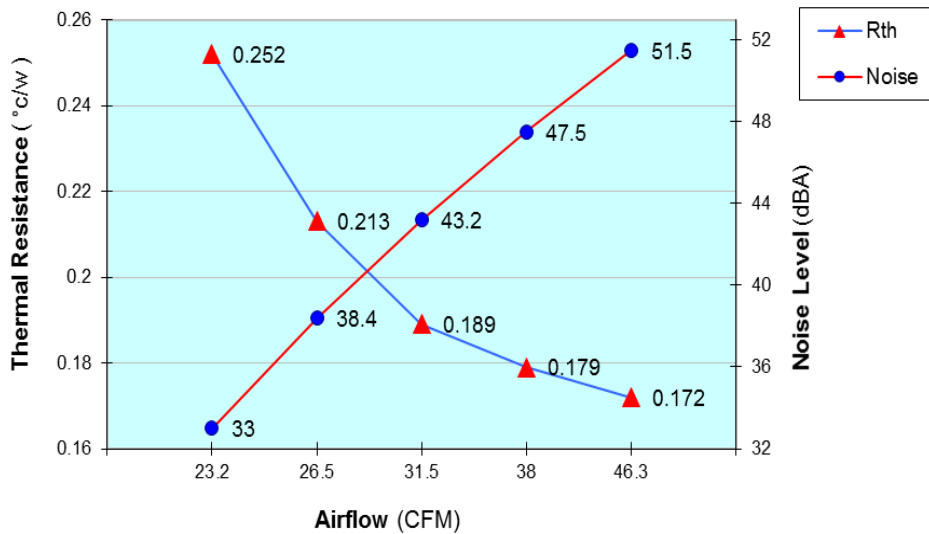

1 2 3 4 5 6 7

| REV# | DESCRIPTION     | CHECKER | DATE     |
|------|-----------------|---------|----------|
| 0.0  | INITIAL RELEASE | LANG    | 05/19/17 |

A

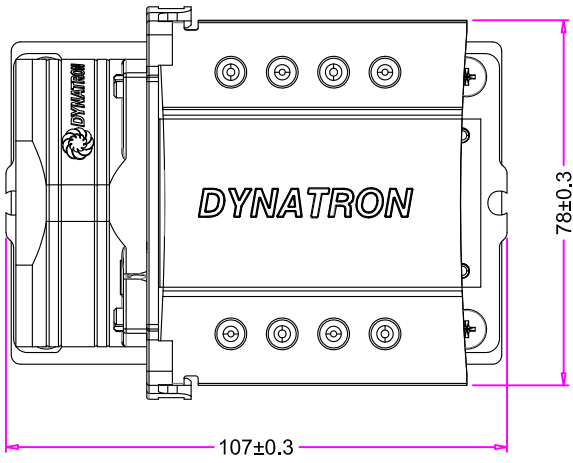

A

B

B

C

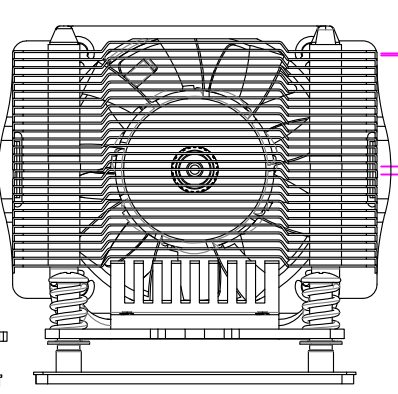
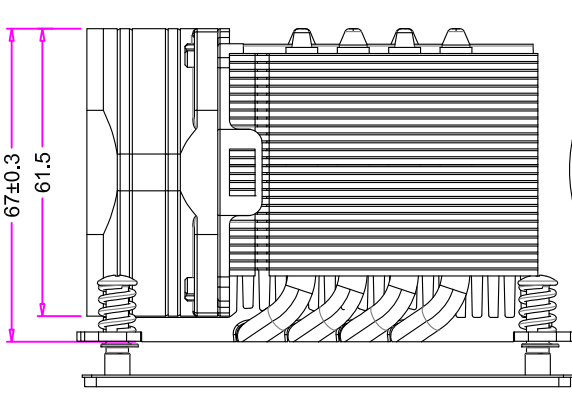
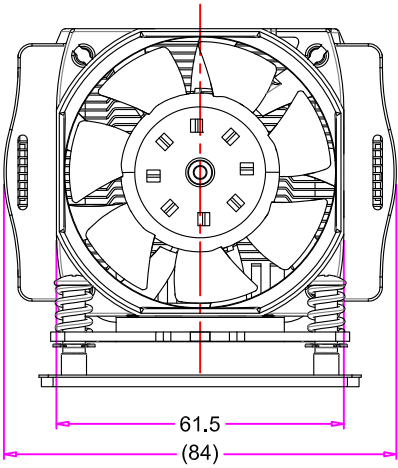

C

D

D

E

E

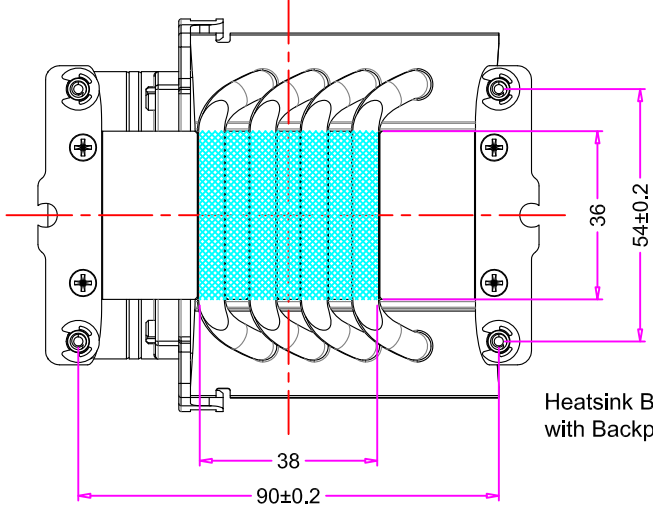
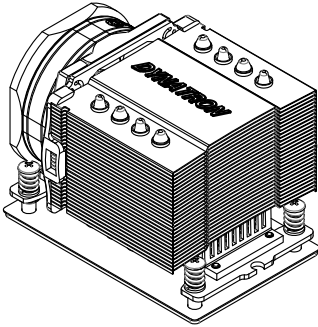

Heatsink Bottom View with Backplate Hidden

F

F

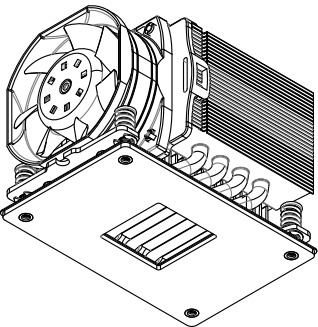

| Item# | Description                   | Material                    | QTY. |
|-------|-------------------------------|-----------------------------|------|
| 11    | Insulator                     | PC, with Dual-Side Adhesive | 1    |
| 10    | Backplate                     | SPCC                        | 1    |
| 9     | Thermal Grease, Pre-Printed   | Shin-Etsu, 7762             | 1    |
| 8     | C-ring                        | Steel                       | 4    |
| 7     | Screw, Heatsink Bracket       | Steel                       | 4    |
| 6     | Bracket                       | SK7, Thk 2.0mm              | 2    |
| 5     | Spring (0940)                 | SWP                         | 4    |
| 4     | Heatsink, Stacked Fin         | Aluminum + Heatplpe         | 1    |
| 3     | Screw, # 6-32 UNC             | Steel                       | 4    |
| 2     | Fan Bracket                   | Plastic                     | 1    |
| 1     | Fan, DF126028BM-PWVG, 7000RPM | Plastic                     | 1    |

G

G

|               | NAME | DATE           |
|---------------|------|----------------|
| DRAWN BY      | enr  | 05 / 19 / 2017 |
| CHECKED BY    | LANG | 05 / 19 / 2017 |
| ENG. APPROVED |      |                |
| MFG. APPROVED | -    | -              |



DYNATRON CORPORATION

TOP MOTOR

TITLE: 2U Active Cooler **A24**  
BOM & Overall Dimension Drawing

H

H

**CONFIDENTIAL DOCUMENT**  
THIS DRAWING CONTAINS INFORMATION PROPRIETARY TO DYNATRON CORPORATION AND DYNAEON INDUSTRIAL CO., LTD. ANY REPRODUCTION, DISCLOSURE, OR USE OF THIS DRAWING IS EXPRESSLY PROHIBITED EXCEPT AS DYNATRON CORPORATION AND DYNAEON INDUSTRIAL CO., LTD. MAY OTHERWISE AGREE TO IN WRITING.

|       |    |                   |            |
|-------|----|-------------------|------------|
| VIEW  |    | DWG. No:          | REV.       |
| UNITS | MM | <b>DYN-BD-A24</b> | <b>0.0</b> |

1 2 3 4 5 6 7